

UNMANNED VEHICLES

COMPONENT MANUFACTURING

Solid Concepts Inc.

solidconcepts.com

661-295-4400

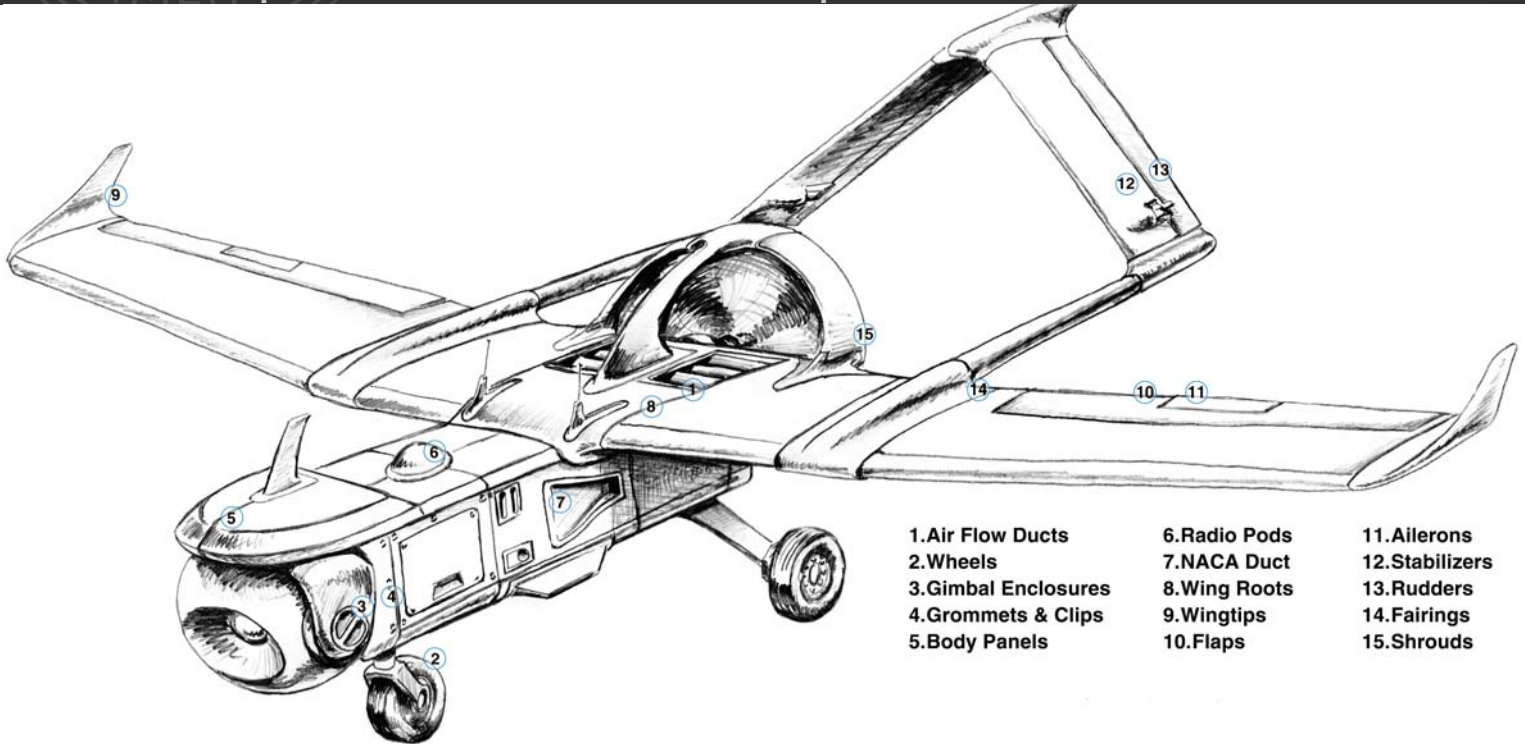

- | | | |
|----------------------|---------------|-----------------|
| 1. Air Flow Ducts | 6. Radio Pods | 11. Ailerons |
| 2. Wheels | 7. NACA Duct | 12. Stabilizers |
| 3. Gimbal Enclosures | 8. Wing Roots | 13. Rudders |
| 4. Grommets & Clips | 9. Wingtips | 14. Fairings |
| 5. Body Panels | 10. Flaps | 15. Shrouds |

THE RIGHT TECHNOLOGY FOR YOUR UNMANNED SYSTEMS APPLICATION

Advanced additive manufacturing technologies such as SLS, FDM and Composite Lay-up allow for the creation of rigid lightweight UAV parts and structures not otherwise achievable with other manufacturing methods. Due to the advancements of these technologies and materials, unmanned vehicles are experiencing performance improvements with superior part design from integrated structures and component consolidation, as well as lighter weight components contributing to endurance enhancements and lower cost for production part development.

Selective Laser Sintering (SLS) is a layer additive manufacturing method that utilizes powdered Nylon 11 and Nylon 12 polyamide materials with property enhancing composite fillers for situations requiring high strength-to-weight ratios. Parts produced are lightweight, highly durable and both heat and chemical resistant. SLS production parts are being used for a variety of end-use and flight rated components for unmanned systems including robust flight surfaces, fuel tanks and air-ducts with integrated structures. FOD

covers, assembly fixtures, drill jigs and alignment tools are other popular applications.

Fused Deposition Modeling (FDM) is a layer additive manufacturing process that uses production-grade thermoplastic materials to produce both prototype and end-use parts. FDM is often used for direct digital manufacturing, and for applications requiring high heat and fire retardant properties. The Ultem-9085 FDM material is flame, smoke and toxicity certified to UL-94V0 and FAA 25.853 standards making it ideal for aerospace applications.

Advanced Composite technologies including **Fiber Reinforced Plastic**, **CompositeCast** and **RTM** are well-suited for projects requiring high strength or where the size of the part makes other technologies unsuitable. These technologies are ideal for lightweight geometries with large, sweeping curved surfaces such as unmanned vehicle body panels. Applications include a single oversized cosmetic cover to a few hundred equipment panels.

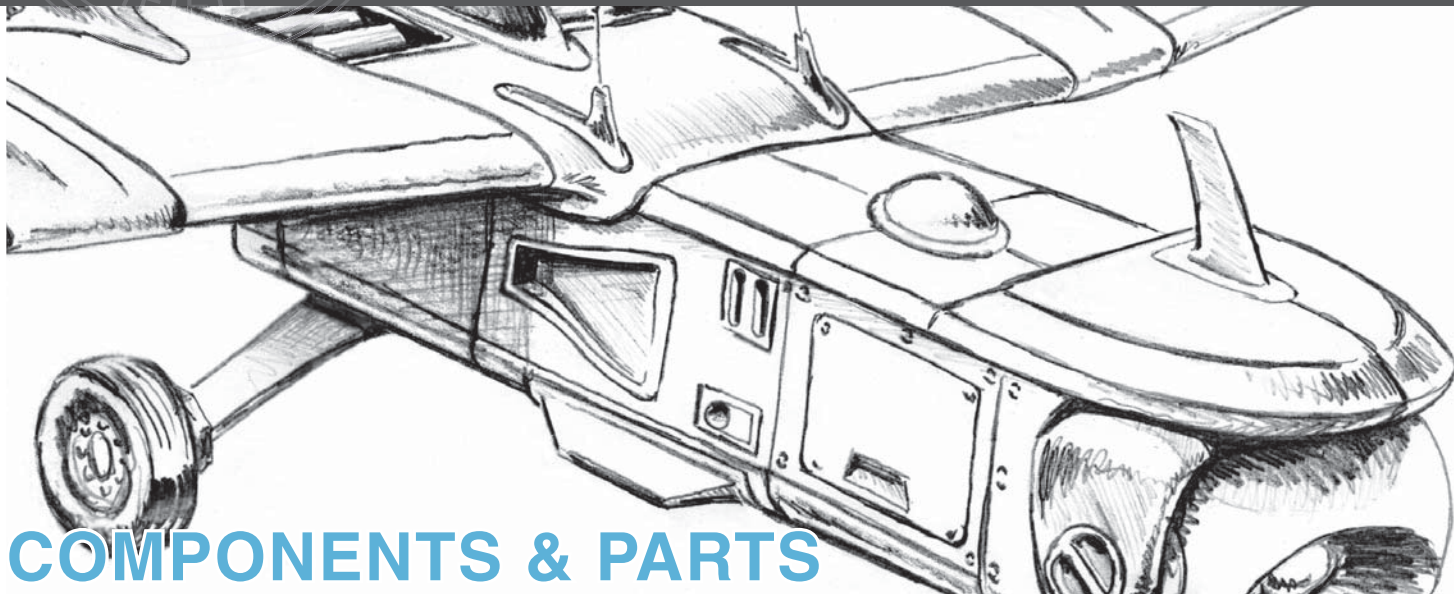

COMPONENTS & PARTS



AIR FLOW DUCTS

Manufacturing of complex multi-component designs can be redesigned as unitized structures utilizing SLS and FDM manufacturing technologies. Designing complex organic and conformal shaped air plenums, vents, NACA ducts and ECS ducts are popular applications well suited to production capabilities additive layer manufacturing.

■ SLS ■ FDM ■ Cast Urethanes



MOUNTING BRACKETS FOR AVIONICS & ELECTRICAL SYSTEMS

Popular applications include mounting brackets for electrical hardware, control mounts, pod enclosures, battery trays with hold-downs, service bay hatches, and close-outs such as FOD protection covers.

■ SLS ■ DMLS ■ FDM ■ Cast Urethanes

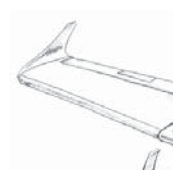

WING AND WINGTIPS

Lightweight complex organic shaped aerodynamic structures can easily be manufactured with FDM and SLS. Successful examples include wing roots (trailing edge & leading edge), winglets & wingtips.

■ SLS ■ FDM ■ Cast Urethanes

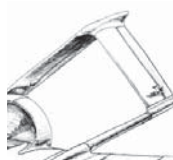

AERODYNAMIC SURFACES

Flaps, ailerons, stabilizers, rudders, flaperons, ruddervators, fairings, shrouds, and seal frames have been successfully manufactured with SLS and FDM technologies. Many such components often include structural supports such as internal ribs and stiffeners to increase the strength to weight ratio as well as providing for integrated mounting configurations.

■ SLS ■ FDM ■ Cast Urethanes



LIQUID & FUEL VESSELS

SLS containers for water, fuel, oil, glycol, antifreeze or hydraulic fluids provide optimized volume of available space with efficient and effective conformal designs. This allows for multiple part reductions and integrated structures while providing weight reductions over conventional assemblies and increasing available volume for liquid storage.

■ SLS



WHEELS

Custom wheels that range in design and size can be manufactured with a wide variety of Cast Urethane materials.

■ Cast Urethanes



GIMBAL ENCLOSURES

Lightweight components for gimbal enclosures can be designed with complex shapes for additive manufacturing.

■ SLS ■ FDM



CLIPS, CLAMPS, GROMMETS

The nest and stack production volume capability of SLS provides an easy way to manufacture clips, clamps, grommets, plugs and spacers on demand.

■ SLS

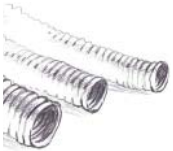

WIRE TRAYS, WIRE WAYS & ELECTRICAL CONDUIT

SLS provides the ability to manufacture conformal wire trays, built-in wire ways, and conformal electrical conduit. These structures can include integrated clips and clamps for quick and easy assembly.

■ SLS ■ Cast Urethanes

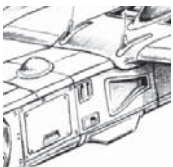

BODY PANELS, FENDERS, BUMPERS

Cast Urethanes and Composites are good for large rigid panels requiring tough, high-impact strength. Cast Urethanes, particularly CompositeCast provide robust, durable skins, cast in color with smooth or textured surfaces.

■ Cast Urethanes ■ Composites ■ FRP



AVIONICS & RADIO ENCLOSURES/ PODS

Enclosures for a variety of components including avionics, radio, video and wiring can be created utilizing Cast Urethane technologies.

■ Cast Urethanes

Need help selecting the best technology and material for your project? Contact Solid Concepts' knowledgeable Project Engineers for guidance at 661-295-4400.

SOLID CONCEPTS INC. SUPPLIER STATUS

As one of the only Rapid Manufacturing Service Providers with a dedicated quality department, Solid Concepts is committed to providing accurate high-quality parts. Our consistent dedication to quality, on-time delivery and customer satisfaction has provided a number of highly sought after awards and honors. Among these recognitions are the Raytheon 3-Star Supplier Award, Honeywell SRR, Boeing Double Gold Performance Rating and Northrop Grumman Platinum Award.

"These ratings demonstrate our commitment to meet the highest quality and delivery standards."

- Beckie Christie, Solid Concepts' Director of Quality



UNMANNED SYSTEMS EXPERTISE

Solid Concepts is the technology leader in the additive manufacturing industry and specializes in using these systems for production of unmanned system components. Our facilities comply with AS 9100 (Austin, TX & Valencia, CA) and ISO 9001 (Poway, CA) certifications.

The quality of product produced at Solid Concepts has earned us an unsurpassed reputation in rapid production and manufacturing for unmanned systems. Countless fortune 500 companies, U.S. Armed Forces & aerospace pioneers continually turn to Solid Concepts for their rapid manufacturing projects.

With 5 U.S. facilities and nine different technologies, Solid Concepts has the capacity, expertise and process controls to meet all your unmanned system needs.

SLS DIRECT DIGITAL MANUFACTURING OF AVIATION FUEL TANKS

The Selective Laser Sintering (SLS) has proven to be ideal for small fuel tanks used in Unmanned Aerial Vehicles and Unmanned Ground Vehicles. In addition to shortened lead time and low production volume cost advantages, SLS fuel tanks can easily incorporate unique design features to improve performance, capacity and reliability. Benefits of Additive Manufacturing:

- Integrated bulkheads, battery mounts, fuel passages and anti-slosh partitions
- Internal passages for wing and longitudinal spars, conduit wireways, pass through hardware, and vent lines
- Designs that maximize volume within organic and conformal shaped structures
- Variable wall thickness and internal support structures for optimizing strength to weight ratios

FUEL TANK MATERIAL CONSIDERATIONS

Nylon-11 based SLS materials are the preferred choice fuel tanks. These polyamide materials build more densely than Nylon-12 based materials and are consequently less porous. Nylon-11 materials have well known success in gasoline, diesel, jet fuel and other petroleum industry applications. To create a more impervious surface, pressure vessels and fuel cells can be internally coated with ITF (Integral Fuel Tank) coatings as required.

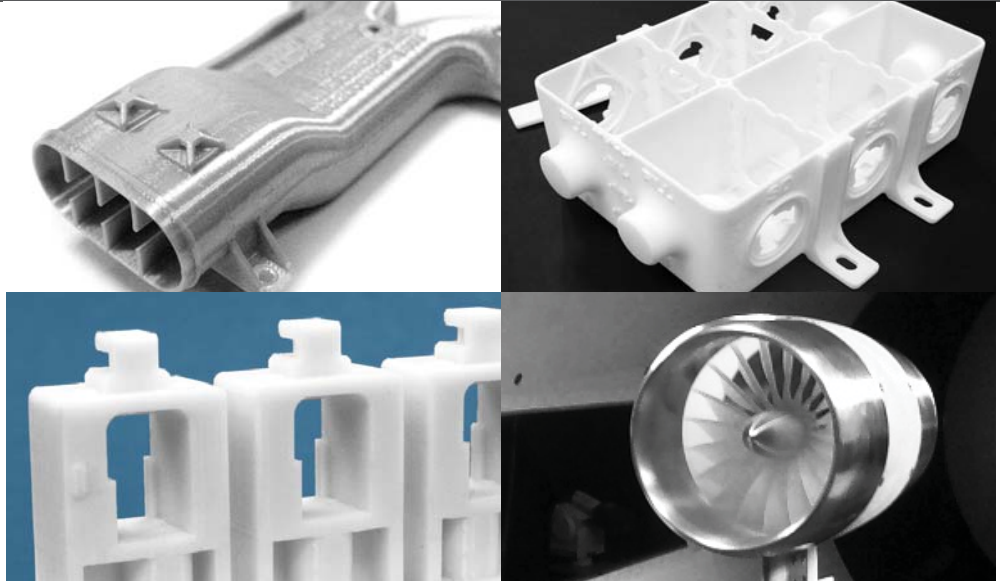

MATERIAL HIGHLIGHTS

High-performance materials optimized for flight and utilized for Direct Digital Manufacturing (DDM).

PA 640 GSL

Light-weight Nylon 12 material enhanced with carbon fiber. High strength-to-weight ratio.

- 30% weight reduction compared to other SLS materials.
- Heat Deflection Temperature 350°F (177°C).
- Flexural Strength 20,400psi; Flexural Modulus 731,000 psi.
- Tensile Strength 7,7100 psi; Tensile Modulus 554,000 psi.
- Electrostatically Dissipative.
- Applications: Horizontal and vertical stabilizers, ailerons, electronic mounts, air flow ducts, conduits, wing tips, avionic mounts and gimballs.

NYTEK™ 1100

Nylon 11 material known to be the world's strongest aliphatic nylon. Boasts exceptional toughness with a combination of durable strength, high abrasion, good fatigue resistance, exceptional chemical and hydrocarbon resistance.

- Lowest water absorption of all commercially available polyamides.
- Outstanding impact strength, even at temperatures below freezing.
- Good chemical and petroleum resistance against fuels, lubricants and salt solutions.
- Good fatigue resistance under high frequency cyclical loading condition.
- High ionization radiation resistance.